

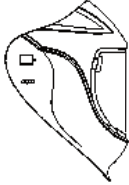

AirShield® AIRPLUS®

HEADTOP USER INSTRUCTIONS
CE Certified according to EN 12941:1998



+



=



ArcONE® is a Division of A.C.E. International Company
85 Independence Drive, Taunton, MA 02780, USA
TEL: +1 (508) 884-9600 • TOLL FREE: +1 (800) 223-4685

Please visit our websites: www.arc1weldsafe.com



EU Declaration of Conformity @ eu.arc1weldsafe.com





Warnings





AirPlus PAPP
CE Approved to BS EN12941 : 1998

RESPIRATORY PROTECTIVE DEVICE - POWERED FILTERING DEVICE, INCORPORATING A WELDING HELMET OR IMPACT PROTECTIVE FACE/SHIELD, CLASS THP R 9 SL DEVICE

USER INSTRUCTION MANUAL

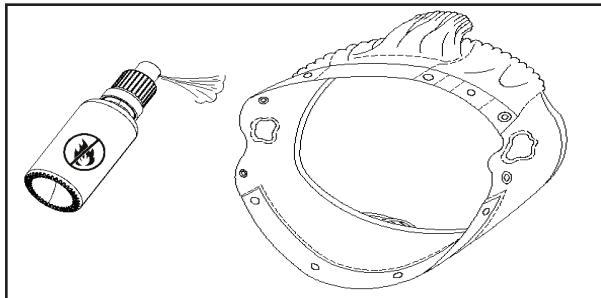
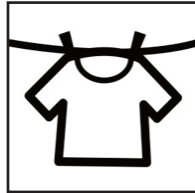
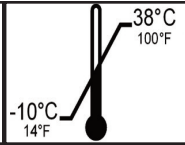
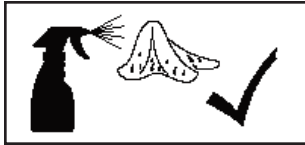
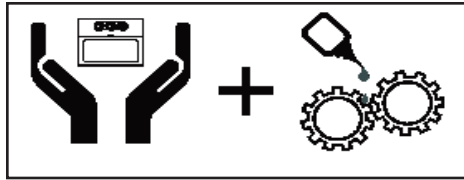
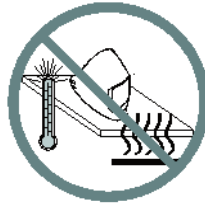
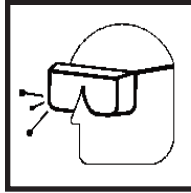

Caution: Always read the manual before using the AirPlus unit.
The manual must be read and fully understood before using the AirPlus unit.
The manual must be retained for future reference.



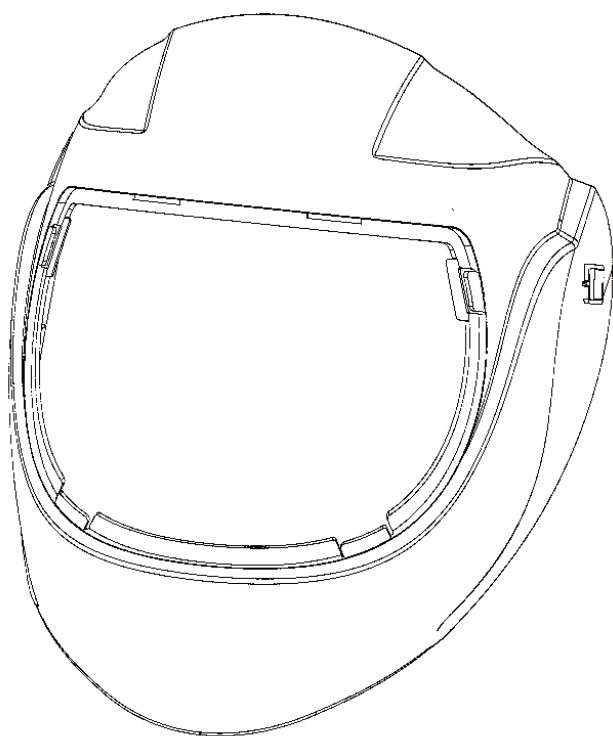
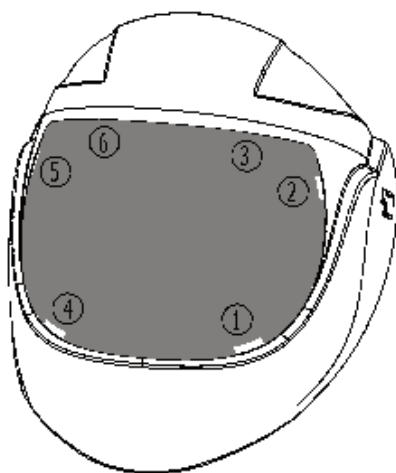
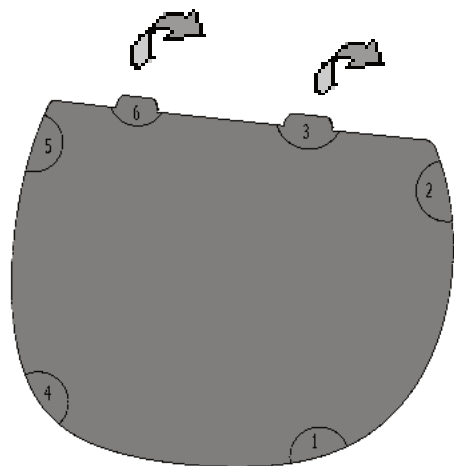
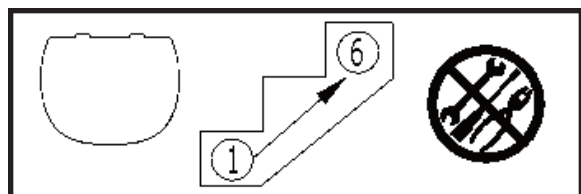

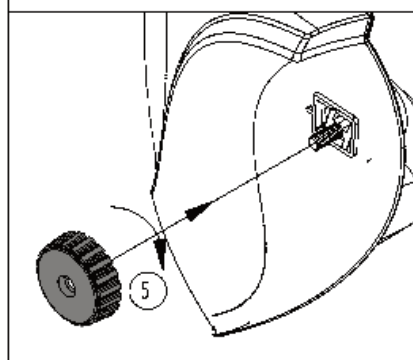
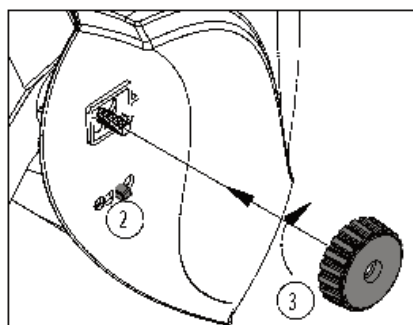
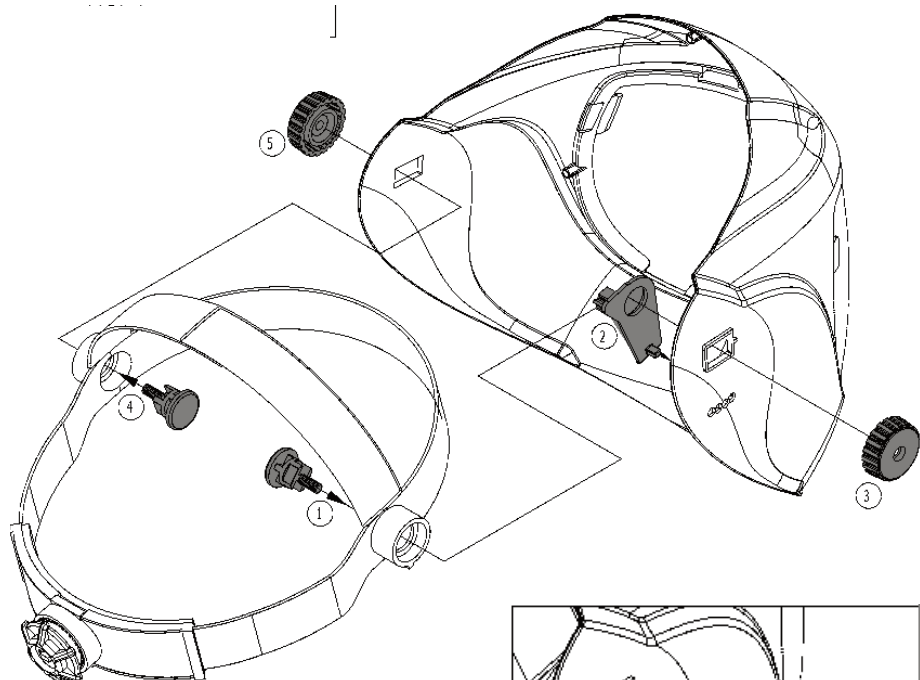
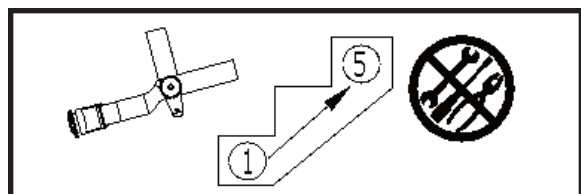

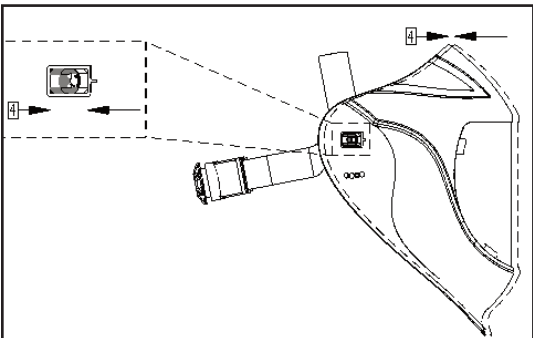
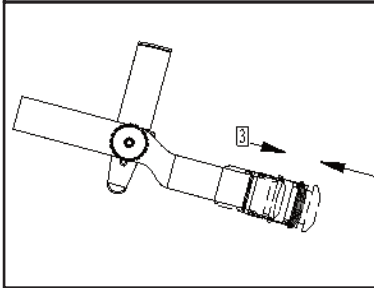
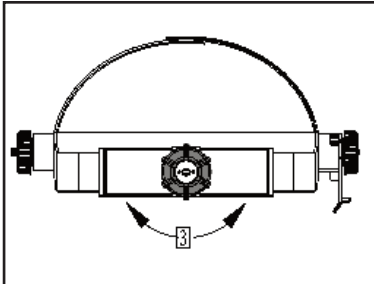
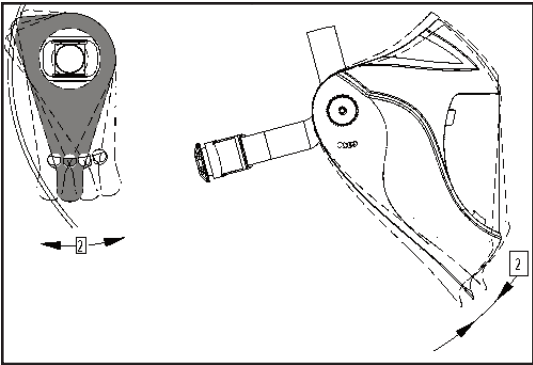
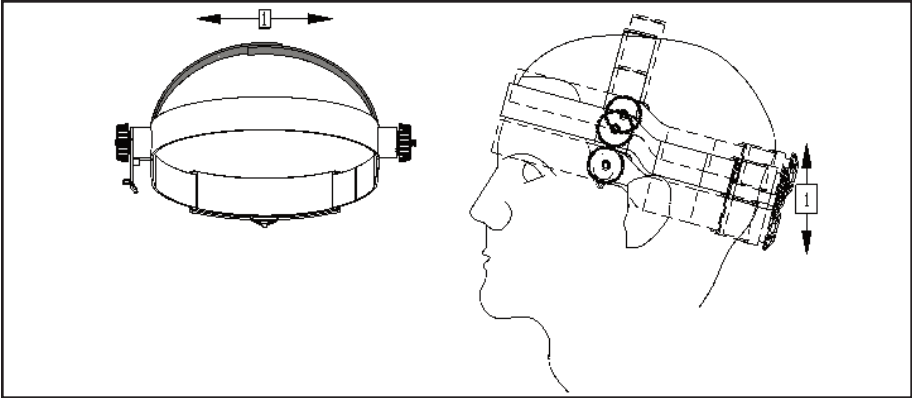
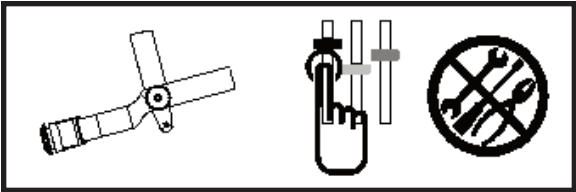

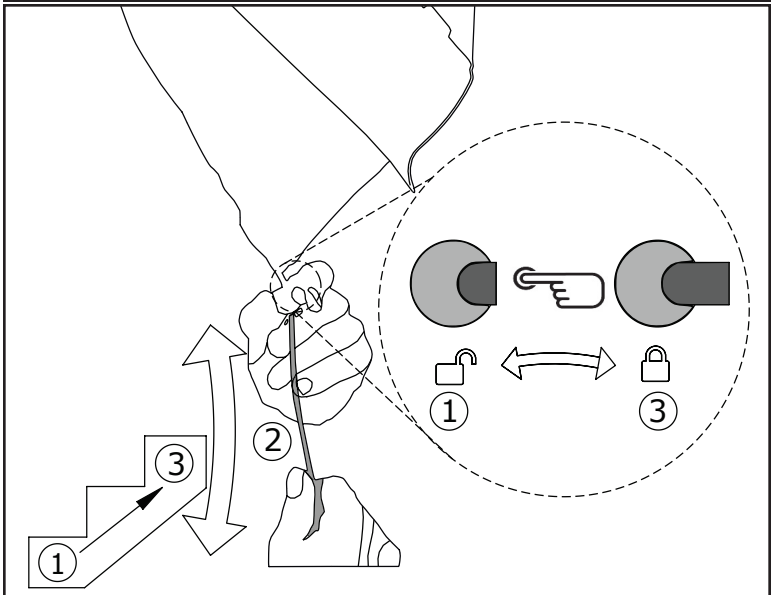
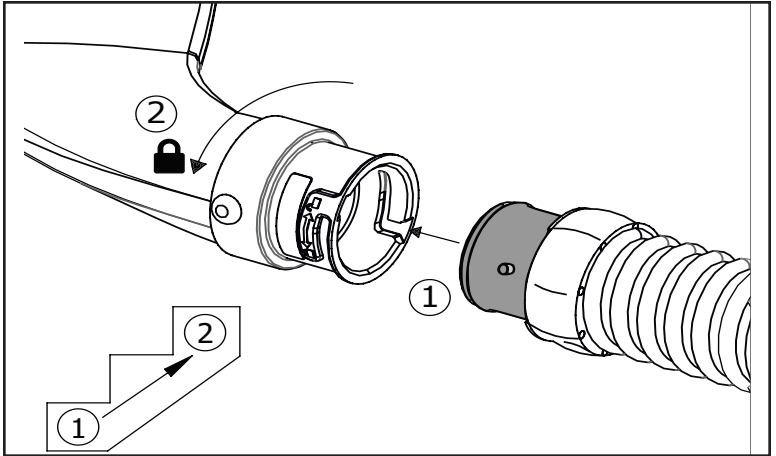
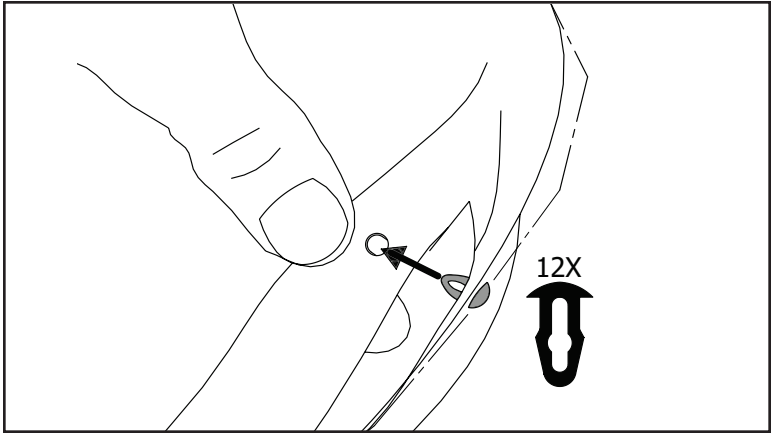

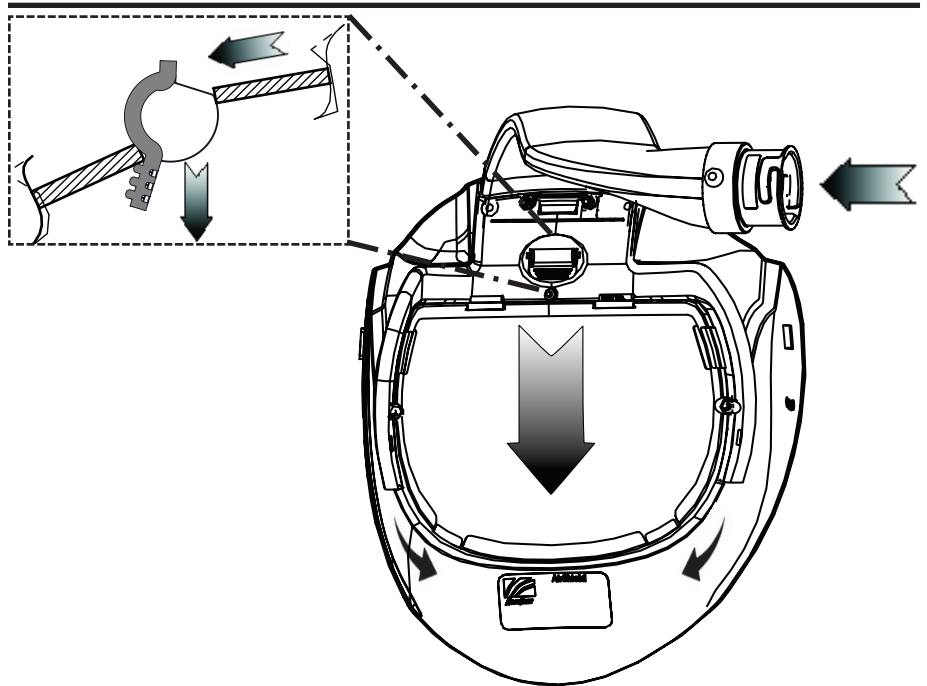
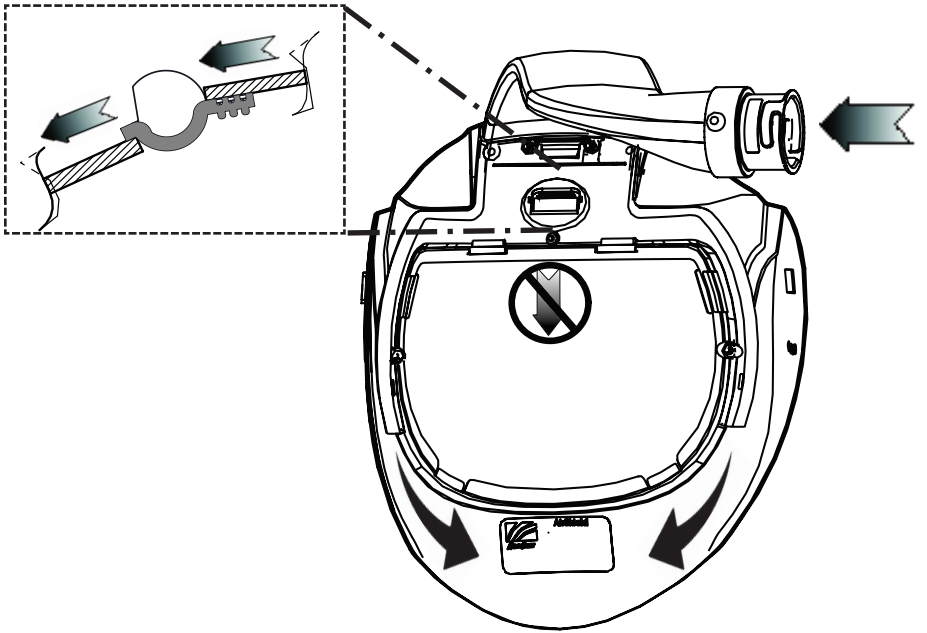
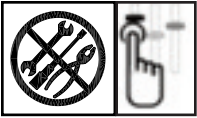

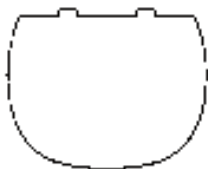

CE EN 166: 1 B AR Z87+ U6

CE = European Mark
EN 166 = CE Eye Protection Standard
1 = Optical Class
B = Impact Class (Medium Energy)
AR = Manufacturer's Mark

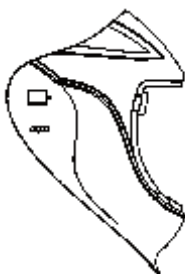

CE = European Mark
EN 166 = CE Eye Protection Standard
-B = Impact Class (Medium Energy)
AR = Manufacturer's Mark

