

USER INSTRUCTION MANUAL



AIRPLUS[®]

Powered Air Purifying Respirator



85 Independence Drive, Taunton, MA 02780
TEL: (508)-884-9600 • TOLL FREE: (800) 223-4685
FAX: (508) 884-9666

AP01-UI Rev D

Definition of Safety Signal Words per ANSI Z535.4



WARNING

Indicates a potentially hazardous situation which, if not avoided, could result in death or serious injury.



CAUTION

Indicates a potentially hazardous situation which, if not avoided, may result in minor or moderate injury. It may also be used to alert against unsafe practices.

! WARNING

Do not use this product until you have read and understood this instruction manual which is an essential part of the *ARCONE® AIRPLUS® PAPP* system.

If the equipment is not properly assembled, connected, and used in strict conformance with this instruction manual, contaminated air could be drawn in the system, resulting in exposure, which may lead, to serious bodily injury or loss of life.

Use by unqualified or untrained persons, or use other than in accordance with this instruction manual, is dangerous and could expose user to serious bodily injury or loss of life.

Do not make any modifications to any part of this system, other than those specified in this manual. Do not use any replacement parts other than those specified in this manual. Unauthorized modifications and replacement parts will void the warranty and expose the user to the risk of personal injury, illness, or loss of life.

Final determination of system applicability and filter selection must be made by an on site safety specialist or industrial hygienist. Not to be used in atmospheres classified as IDLH (Immediately Dangerous to Life or Health).

Not to be used in atmospheres containing less than 19.5% oxygen.

TABLE OF CONTENTS

1.0 General Information

- 1.1 Introduction
- 1.2 Operating Principles
- 1.3 Respirator Approvals and Limitations
- 1.4 Helmet and Welding Filter Approvals and Limitations

2.0 System Use

- 2.1 Preparation for Safe Use
- 2.2 Battery
- 2.3 Filters
- 2.4 Blower
- 2.5 Airflow Test
- 2.6 Headtop
- 2.7 Waist Belt
- 2.8 Pre-Operational Inspection
- 2.9 Wearing (Donning) PAPR
- 2.10 Removing (Doffing) PAPR
- 2.11 Troubleshooting

3.0 Inspection, Maintenance and Storage

- 3.1 Record Keeping
- 3.2 Cleaning
- 3.3 Inspection
- 3.4 Storage

4.0 Replacement

- 4.1 Battery
- 4.2 Filter
- 4.3 Blower
- 4.4 Breathing Tube
- 4.5 Face Seal
- 4.6 Waist Belt
- 4.7 Special Instructions

5.0 Customer Information

- 5.1 Replacement Parts and Accessories
- 5.2 Technical Specifications
- 5.3 Warranty and Technical Service Information

AIRFLOW DIAGRAM



A Complete *ARCONE® AIRPLUS®* System Includes:

- Welding Helmet Headtop with Face Seal
- A Choice of Auto-Darkening Welding Filters
- One (1) HE Particulate Filter
- Blower Unit
- 7.4V Lithium-Ion Battery and Charger
- Breathing Tube with Flame Retardant Cover
- Adjustable Waist Belt
- Airflow Indicator (not shown)
- Carrying Case (not shown)

1.0 General Information

1.1 Introduction

Thank you for your purchase of the **ARCONE® AIRPLUS®** Powered Air Purifying Respirator (PAPR) system. Available with the system is the complete **ARCONE®** family of electronic Auto-Darkening Filters (lenses). See the enclosed Respirator Approval Label for a complete list of lens assemblies.

The **ARCONE® AIRPLUS® PAPR** system blows a supply of filtered air over the welder's face, creating a protective positive pressure inside the face seal that keeps out harmful particulates and mist. The PAPR system is engineered for safety, function, and lightweight comfort. To ensure your safety and complete satisfaction with the **ARCONE® AIRPLUS® PAPR** system, please read these instructions thoroughly before use. Please, also, read the **ARCONE®** Auto-Darkening Filters User Instruction Manual that accompanies your Headtop.

1.2 Operating Principles

The **ARCONE® AIRPLUS® PAPR** system is used in an environment requiring protection against harmful particles and mist. Used in conjunction with an **ARCONE®** Auto-Darkening Filter and welding helmet, it eliminates wasted motion and discomfort associated with welding. You will receive a constant flow of fresh air, which will allow you to comfortably remain safe in your work environment for a longer period of time, and is of particular benefit where working conditions are hot or humid.

The **ARCONE® AIRPLUS®** Lithium-Ion battery provides power for an eight (8) hour shift when the blower is set on low fan and a six (6) hour shift when the blower is set on high fan. This rechargeable battery is encased in durable lightweight plastic and attaches securely to the blower unit. The charging time for a fully discharged battery is 5-7 hours. The battery may be received partially charged and should be fully charged before use. (Section 2.2 Battery Charging.)

The **ARCONE® AIRPLUS®** HE filter is designed to be used with the blower unit. Make sure your PAPR system is fitted with a filter appropriate to the application and selected by a competent person with a full knowledge of respiratory hazards, and their concentrations that are applicable in the workplace. To ensure adequate protection, it is essential that the blower unit is correctly configured and that the correct filter is used. (Section 2.3 Filters.)



If there is any doubt of final determination of respirator applicability and filter selection, it must be made by an on-site safety specialist or industrial hygienist.

For OSHA's on-site consultation call 1-800-321-OSHA (6742) or contact the National Institute of Occupational Safety and Health for more information at www.cdc.gov/niosh.

1.3 Respirator Approvals and Limitations

The **ARCONE® AIRPLUS® PAPER** system as described in this instruction manual has been approved by NIOSH (National Institute for Occupational Safety and Health) to the following standard: NIOSH 42 CFR Part 84 (USA, See Enclosed Approvals).



Special User Instructions

1. Improper respirator use may cause injury or death. Improper use may also cause certain life-threatening delayed lung diseases. Regulations require the employer provide training to the user on proper use, maintenance and limitations of **ARCONE® AIRPLUS® PAPER** system.
2. Each person using these respirators must first read and understand this instruction manual.
3. Before using **ARCONE® AIRPLUS® PAPER** system, be sure your employer has determined airborne contaminant concentrations do not exceed those allowed by applicable OSHA, MSHA, EPA, NIOSH or ACGIH regulations for powered air purifying respirators. Federal law requires your employer measure and monitor airborne contaminant levels in the work area.
4. Failure to use components and replacement parts approved by NIOSH for use with this PAPER system voids NIOSH approval of the entire respirator, invalidates all **ARCONE® AIRPLUS® PAPER** warranties, and may cause death, lung disease or exposure to other hazardous or life-threatening conditions.
5. Inspect all components of the **ARCONE® AIRPLUS® PAPER** system during cleaning and before and after each use for signs of wear, tear or damage that might reduce the degree of protection originally provided. Immediately replace worn or damaged components with **ARCONE® AIRPLUS® PAPER** components approved by NIOSH for use with this PAPER system.
6. DO NOT use the **ARCONE® AIRPLUS® PAPER** system in inadequately ventilated areas, where oxygen is less than 19.5%, or in confined spaces such as tanks, small rooms, tunnels or vessels unless the confined space is well-ventilated and contaminant concentrations are below the recommendations for this system. The procedures for confined space entry, operation and exit are defined in applicable regulations and standards, including 29 CFR 1910.146.

CAUTIONS AND LIMITATIONS

- A- Not for use in atmospheres containing less than 19.5% oxygen.
- B- Not for use in atmospheres immediately dangerous to life or health.
- C- Do not exceed maximum use concentrations established by regulatory standards.
- F- Do not use powered air-purifying respirators if airflow is less than four cfm (115 lpm) for tight fitting facepieces or six cfm (170 lpm) for hoods and/or helmets.
- I- Contains electrical parts that may cause an ignition in flammable or explosive atmospheres.
- J- Failure to properly use and maintain this product could result in injury or death.
- L- Follow the manufacturer's User's Instructions for changing cartridges and/or filters.
- M- All approved respirators shall be selected, fitted, used, and maintained in accordance with MSHA, OSHA, and other applicable regulations.
- N- Never substitute, modify, add, or omit parts. Use only exact replacement parts in the configuration as specified by the manufacturer.
- O- Refer to User's Instructions, and/or maintenance manuals for information on use and maintenance of these respirators.
- P- NIOSH does not evaluate respirators for use as surgical masks.

AIRPLUS® PAPR

Additionally: **DO NOT WEAR THIS RESPIRATOR IF ANY OF THESE CONDITIONS EXIST:**

- You CANNOT escape without the aid of the respirator.
- Work area is inadequately ventilated.
- Unknown contaminants are present.

This **ARCONE® AIRPLUS® PAPR** system is only part of an overall OSHA Respirator Program, which contains the following documentation:

1. Administration
2. Use of Respirators
3. Selection of Respirators
4. Employee Training, Instructions, and Discipline
5. Inspection, Cleaning, Storage, and Repair
6. Emergency Use Respirators
7. Program Evaluation

1.4 Helmet and Welding Filter Approvals and Limitations

The **ARCONE®** welding helmet Auto-Darkening Filters have been tested to:

- ANSI Z87.1. Limitations: See Auto-Darkening Filter User Instruction Manual.

2.0 System Use

2.1 Preparation for Safe Use

Before using the **ARCONE® AIRPLUS® PAPR** system you should ensure that all conditions for safe use have been satisfied. Refer to Section 1.3 and Approval Labels (enclosed).

2.2 Battery

The Lithium-Ion battery included with your system does not need to be manually discharged.

Charge/Recharge Battery:

1. Turn off the blower if the battery is connected to the blower. (Note: the battery may be either connected to or disconnected from the blower unit to recharge.)
2. Connect the charger to the battery (Fig.1).

Indicators on charger as follows:

- Solid Red LED - Charging
- Solid Green LED - Charge Complete
- Flashing Red LED - Fault (Section 2.11)

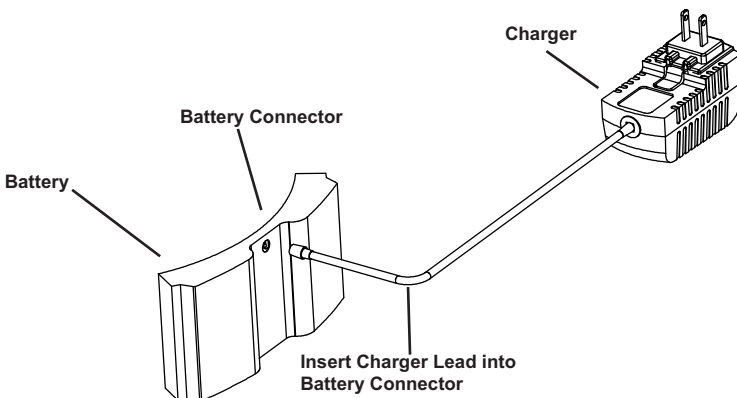

Figure 1

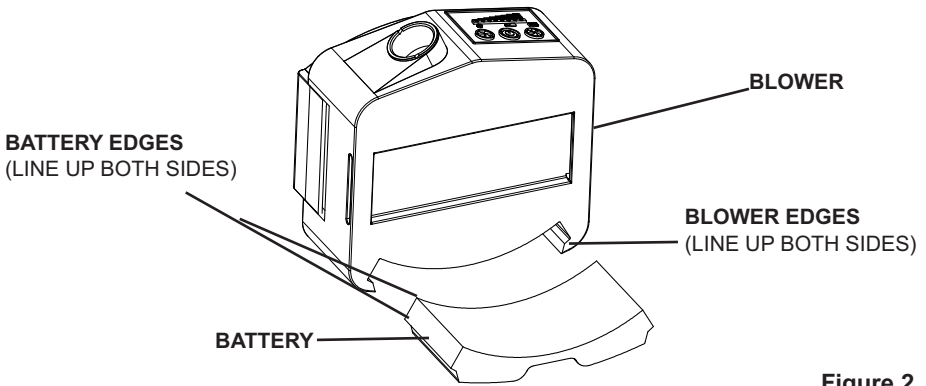

Figure 2

Battery Installation:

1. Line up the edges as shown (Fig. 2).
2. Slide the battery into the blower.
3. Make sure there is an audible click as the battery locks into the blower.

2.3 Filters

Read the enclosed NIOSH approval labels for proper part selection before installing the filter into your *ArcONE® AIRPLUS®* PAPR system. **Change the filter when it becomes dirty or when proper airflow cannot be maintained (see Section 2.5 Airflow Test)**

! WARNING

THIS FILTER IS NOT MEANT TO BE REUSED. DO NOT CLEAN AND REUSE. THE FILTER SHOULD NEVER BE USED FOR PROTECTION AGAINST GASES OR VAPORS. REFER TO SPECIFIC NIOSH FILTER APPROVAL LABELS FOR SPECIFIC INFORMATION ON USAGE AND LIMITATIONS.

Filter Installation:

1. Remove any filter packaging from the filter.
2. Open the filter cover (Fig. 3).

Pull Tab on Cover Away from Blower
(pull the right side of cover)

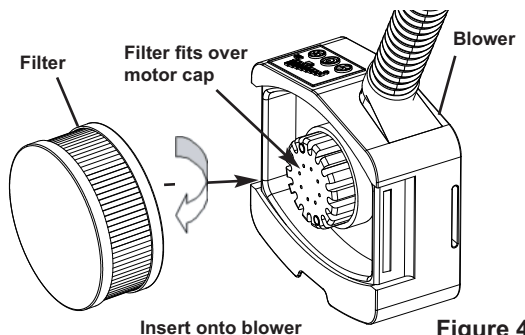

3. Remove the old filter (if installed) with a slight twisting motion as you pull it away from blower.
4. Install the new filter onto the blower using the same rotating motion as you push (Fig. 4).
5. Close the filter cover onto the blower, making sure the right tab snaps onto the blower.
6. Check that the filter cover is secured.

2.4 Blower

1. Install the Breathing Tube into the Blower as shown (Fig. 5).
2. Operate the Blower (Fig. 6).

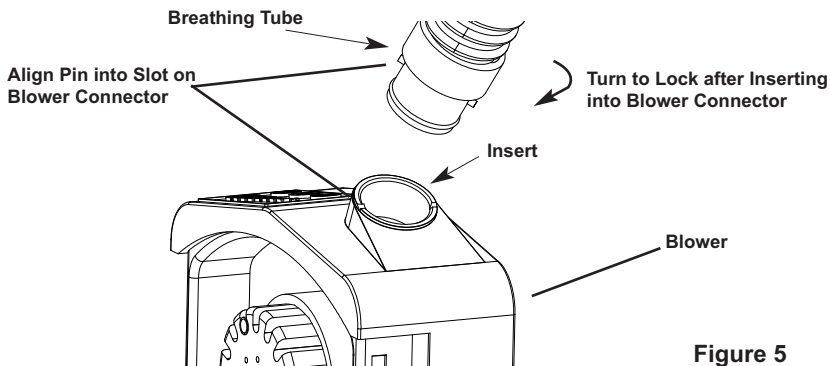

Figure 5

Become familiar with the operation of your **ARCONE® AIRPLUS®** PAPR system blower unit before initial operation. The controls operate as follows:

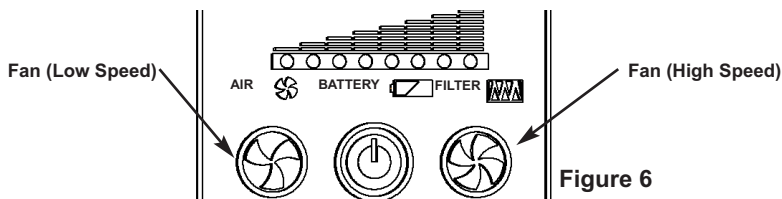

Figure 6



Power Button - turn the blower unit on or off.



High Speed Fan - increase airflow indicated by GREEN LED panel above power button.



Low Speed Fan - decrease airflow indicated by GREEN LED panel above power button.

Filter/Airflow status indicated with GREEN LEDs.

Filter/Airflow status: GOOD.

Filter/Airflow status: Near Full.

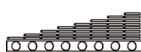

Battery: When blower is turned on the LEDs will flash RED. The life of the battery corresponds to the amount of lights flashing RED. (ALWAYS begin each shift with a fully charged battery.)

Audible Alarm: Airflow blocked/change Filter soon.

Audible Alarm plus Vibration: Airflow blocked/Replace Filter.

Audible Alarm (short beep) & RED LEDs flash: RECHARGE BATTERY.

2.5 Airflow Test

1. Connect one end of the Breathing Tube to the Blower Unit.
2. Connect the Airflow Indicator to the free end of the Breathing Tube (detach from Airduct, if applicable) (Fig. 7 and 8).
3. Turn on the Blower Unit and set the fan speed to the lowest airflow setting (Section 2.4).
4. Hold the Breathing Tube and Airflow Indicator vertically.
5. The airflow is sufficient only if the indicator ball reaches the minimum flow rate level (Fig. 8).
6. If the Airflow Indicator ball sits below the minimum flow rate level, it is necessary to charge the battery or change the filter (Sections 2.2 & 2.3).



FAIL
X

Figure 7



PASS
✓

Figure 8

2.6 Headtop

1. Install and lock the breathing tube into the airduct on the Headtop (Fig 9).
2. Don the Headtop over your face. Adjust the headgear ratchet wheel by pushing in and turning until a satisfactory tightness is achieved.
3. Adjust the Face Seal fit with the pull cord by pressing on the lock and adjusting the cord length until a tight fit is achieved between your face and the Face Seal.

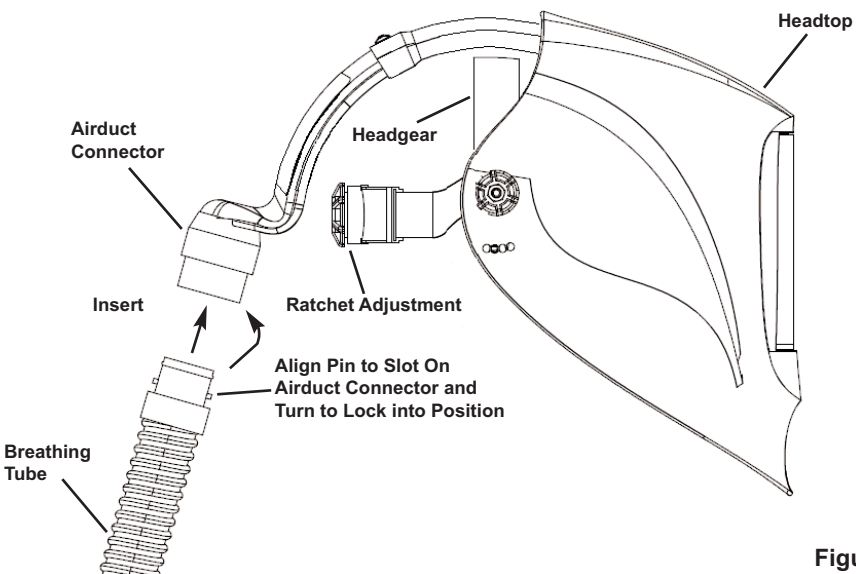

Figure 9

2.7 Waist Belt

1. Clip Waist Belt with blower onto your back and the Breathing ube pointing upwards (Fig.10).
2. Adjust free end of belt strap to tighten or loosen.

2.8 Pre-Operational Inspection

Check the following before donning your *ARCONE® AIRPLUS® PAPR* system. If any of the following are not in compliance refer to the section for use and/or maintenance.

1. Location where *ARCONE® AIRPLUS® PAPR* System is used contains and maintains at least 19.5% oxygen.
2. The location **DOES NOT** contain explosive gases or vapors.
3. The selected filter meets NIOSH guidelines for the applicable contaminant (see NIOSH Pocket Guide to Chemical Hazards available from NIOSH).
4. Battery is fully charged and installed on the blower unit.
5. Filter is installed in the blower unit and the filter cover is secured.
6. Breathing Tube is connected and secured to the Blower unit.
7. Breathing Tube is connected and secured to the Headtop.
8. Face Seal is installed and secured to the Headtop.
9. Face Seal and helmet are free of holes, runs, cuts, and tears.
10. Face Seal is clean and free of contaminants.
11. Blower is operational and once turned on check that:
 - a. The Battery status is above recharge (Section 2.4).
 - b. The Filter/Airflow status is good and the airflow is not obstructed (Section 2.4 & 2.5).
 - c. Attach Breathing Tube to Airduct and confirm that there is airflow into the Headtop.



Figure 10

CAUTION

DO NOT use a clogged or damaged HE filter. Change the HE Filter after 40 hours of use or when proper airflow cannot be maintained (Section 2.5), whichever occurs first.

WARNING

DO NOT don *ARCONE® AIRPLUS® PAPR* system before completing the Pre-Operational Inspection (Section 2.8).

BREATHING MAY BE IMPAIRED IF THE HEADTOP IS DONNED WITHOUT PROPER AIRFLOW FROM THE BLOWER UNIT.

CAUTION

Excessive facial hair may cause an incomplete seal. When in doubt remove excessive facial hair where it interferes with the seal between the users face and the face seal.

WARNING

Failure to properly connect the Breathing Tube to the Headtop Assembly and confirm airflow through system to the Breathing Zone could lead to contaminant exposure resulting in serious bodily injury or loss of life.

2.9 Wearing (Donning) PAPR

To don the *ARCONE® AIRPLUS®* PAPR system, do the following in the order listed:

1. Perform the Pre-Operational Inspection (Section 2.8).
2. Turn on Blower unit and ensure proper airflow (Section 2.4).
3. Secure the Blower unit with Waist Belt to your body (Fig. 10).
4. Ensure airflow into the Headtop.
5. Don the Headtop and adjust the Headgear using the ratchet adjustment knob (Fig. 9).
6. Fit check the Face Seal and adjust tightness for best seal and comfort.

WARNING

LEAVE WORK AREA IMMEDIATELY IF:

- Any respirator component becomes damaged.
- Airflow into the respirator welding helmet stops or any alarms sound (Section 2.4).
- Breathing becomes difficult.
- You experience dizziness, nausea or illness.
- You taste, smell or see contaminants inside the respirator.
- If you feel eye or throat irritation.

2.10 Removing (Doffing) PAPR

1. Leave the contaminated area and go into a non-contaminated breathable air area.
2. Loosen the Headgear front to back adjustment knob before removing Headtop.
3. Remove Headtop.
4. Unclip Waist Belt and remove from waist.

2.11 Troubleshooting

Problem	Possible Cause(s)	Solution
Reduced / No Airflow	Blower unit off	Turn blower unit on
	Blocked Breathing Tube	Remove obstruction/Check for holes
	Blocked Airduct or Blower	Remove obstruction
	Leak in Airduct or Breathing Tube	Replace defective Airduct and/or Breathing Tube
	Filter clogged	Replace filter
	Battery charge low	Recharge battery
	Battery defective	Replace battery
	Battery not connected	Check battery to blower connection & battery is snapped in place
Blower does not turn on	Battery not installed	Install battery
	Battery not charged	Recharge battery
	Defective switch	Contact ARCONE® Technical Support (800) 223-4685
	Motor defective	Contact ARCONE® Technical Support (800) 223-4685
Battery fails to charge	Check outlet voltage	Connect to good 110 Volt outlet
	Defective charger	Contact ARCONE® Technical Support (800) 223-4685
	Defective battery	Contact ARCONE® Technical Support (800) 223-4685
Short operating time	Clogged Filter or Battery is not charged properly	Change filter / charge battery. (if problems persists Contact ARCONE® Technical Support (800) 223-4685)

3.0 Inspection, Maintenance and Storage

3.1 Record Keeping

All components should be checked daily when used regularly. Regardless of the usage, each respirator system requires a documented inspection and replacement program. A trained and competent person with full knowledge of respiratory equipment should carry this out. Records should be maintained throughout the life of the equipment. Regulatory Guidance can be found in the following documents: OSHA 29CFR 1910 Part 134 and ANSI Z88.2.

Use only **ARCONE® AIRPLUS® PAPR** components and replacement parts manufactured by **ARCONE®** and approved by NIOSH for use with the respirator system. Inspect all components of the respirator system during cleaning, and before and after each use for signs of wear, tear or damage that might reduce the degree of protection originally provided. Respirators used by more than one person must be cleaned, inspected, and sanitized after each use. If not cleaned, contamination may cause illness or disease. Allow components to air dry before reassembling.

3.2 Cleaning

1. ALWAYS INSPECT your **ARCONE® AIRPLUS® PAPR** system before each use and after cleaning. Clean the external surfaces of the PAPR system with a soft cloth dampened in a mild solution of clean water and mild detergent. Never use abrasive cleaners. During cleaning, ensure that NO water is allowed to enter into the blower unit or battery pack as this could damage the blower or battery internal parts. Never immerse the unit in liquid.
2. Detach the Breathing Tube from the Blower unit and the Headtop (Section 4.4), and wipe the connection sites.
3. Detach the Face Seal from the Headtop before cleaning (Section 4.5). Hand wash in a mild solution of clean water and mild detergent. Allow the Face Seal to air dry before reattaching to the Headtop.
4. Allow all components to dry away from direct heat.
5. Refer to the **ARCONE®** Auto-Darkening Filters manual for maintenance of applicable components.

WARNING

Do not clean the HE filter by any means including forced air. Doing so will damage the filter and void the Blower Unit warranty. Change the HE filter after 40 hours of use or when proper airflow cannot be maintained.

WARNING

Do not allow contaminants to enter into the breathing tube or blower unit. Failure to prevent contaminants from entering into the **ARCONE® AIRPLUS® PAPR system could lead to contaminant exposure resulting in serious bodily injury or loss of life. Consult your local safety professional in event contaminant entry into the breathing tube or blower unit is suspected.**

WARNING

Do not allow water to enter into the blower unit or the battery pack. Failure to prevent water from entering into the blower unit or battery pack could cause the product to fail, leading to contaminant exposure resulting in serious bodily injury or loss of life. Any filter, which has been directly exposed to water, must be disposed of in accordance with state, local, and federal ordinances.

Do not clean any part of the system with gasoline, organic based solvents or chlorinated degreasing fluids (such as trichloroethylene). Use of these substances could lead to contaminant exposure and/or product failure resulting in serious injury or loss of life.

3.3 Inspection

1. Before each use and after cleaning (Section 3.2), inspect the individual parts and ensure that all components and connection sites are clean and in good condition.
2. Inspect for damages such as holes, cracks, and scratches on all parts. If in doubt of effective respiratory performance replace the parts with only **ARCONE®** approved parts for this system.
3. Additionally, inspect the following:
 - a. Blower unit: Button function. Replace blower if damaged.
 - b. Breathing Tube:
 - O-ring state. Replace if worn/cut, torn, or if in doubt as to condition.
 - Check for holes or splitting. When in doubt, replace the Breathing Tube.
 - NEVER patch the Breathing Tube.
 - c. Face Seal: ensure that the Face Seal has not lost its elasticity and that there are no tears or holes. Replace if in doubt as to the condition of the Face Seal.
 - d. Waist Belt: ensure the clip securely snaps together.

3.4 Storage

1. Before storing the **ARCONE® AIRPLUS® PAPR** system, it should be thoroughly dry. Do not keep used filter in the same enclosed storage space as new filters.
2. Store the system in a clean area, away from moisture, heat and direct sunlight. Storage temperatures 32°F-104°F (0°C-40°C and <75% Relative Humidity).
3. Filter Storage (if provided, refer to manufacturer's instruction manual):
 - a. Store between 0°-40°C
 - b. Expires xxxx/xx (xxxx= year, xx= month)
 - c. Maximum storage humidity: 75%

4.0 Replacement

4.1 Battery

Removal (Fig. 11):

1. Pull up on the snap tab.
2. While holding the snap tab away from the blower pull the battery in the direction indicated.

Installation (Section 2.2 and Fig. 2.)

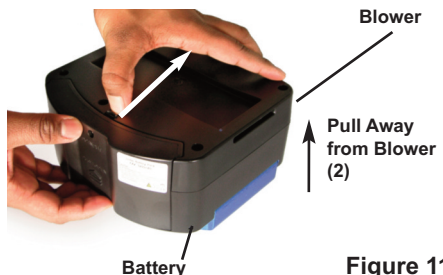

Figure 11

WARNING

DO NOT store respirator system in your work area or leave it unattended in a contaminated environment. Respirable contaminants can remain suspended in the air after work activity ceases, even though you may not see them. Proper work practice requires you to wear the respirator until you are outside the contaminated environment. If you set the respirator down in a contaminated area, contaminants, dirt and dust could get into the respirator. When you don the respirator again you could breathe contaminants upon reuse.

4.2 Filter

Removal & Installation: refer to Section 2.3

4.3 Blower

Note: The blower unit, battery, and battery charger are not user serviceable. Maintenance or replacement of parts should only be performed by *ARCONE®*, who has the necessary test equipment to ensure that all repairs are completed safely and recertified.

4.4 Breathing Tube

Removal:

1. Turn the Breathing Tube connector counter clockwise and pull out of the Blower.
2. Turn the Breathing Tube connector clockwise and pull out of the Headtop.

Installation: refer to Section 2.4 (Fig 5).

CAUTION

The Blower and Battery Units are supplied as seal-tested units. Any attempt to open or repair the unit will result in the termination of the limited warranty contained in Section 5.3

4.5 Face Seal

Removal: (Phillips screw driver needed)

1. Remove the Headgear by removing knobs on each side of the Headtop (Fig.12).
2. Locate and unscrew the seven screws surrounding the Headtop (Fig.13). Save screws and nuts.
3. Carefully pull the Face Seal away from the Headtop.



Figure 12

AIRPLUS® PAPR

Installation:

1. Align the Face Seal with the seven holes surrounding the Headtop (Fig.13).
2. Be sure to place the pull string on the bottom of the Headtop (Fig. 14).
3. Use the screwdriver to screw in the seven screws tightly into their respective holes and nuts.



Figure 13



Figure 14

4.6 Waist Belt

Removal:

1. Remove the Waist Belt from the clip.
2. Unthread the Waist Belt Strap from the Blower.

Installation:

1. Thread the Waist Belt Strap through the side slots on the Blower (Fig. 15).
2. Thread the Waist Belt Strap through the belt loops (Fig. 16).
3. Thread the Waist Belt strap through the Clip and pull tight to secure the Blower to the Waist Belt (Fig. 17).



Figure 15

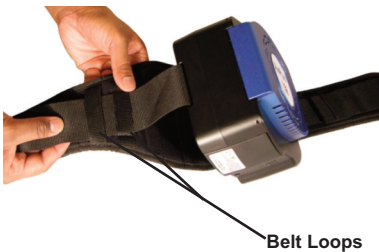

Figure 16



Figure 17

5.0 Customer Information

5.1 Replacement Parts and Accessories

To order replacement parts or accessories, use the part numbers and descriptions listed below. Failure to use only **ARCONE® AIRPLUS® PAPR** system parts and accessories will void the NIOSH Approval and **ARCONE's** warranty and may expose the user to the risk of serious bodily injury or loss of life. **ARCONE®** is not responsible for system performance if components other than **ARCONE® AIRPLUS® PAPR** system parts are used to repair or refurbish the equipment. See the **ARCONE®** Auto-Darkening Filters User Instruction Manual for specific replacement parts that are not included in this manual.

NOTE: The NIOSH Approval covers complete respirator systems only, which are configured from approved components as referenced on the NIOSH Approval Label for the applicable systems.

Powered Air Purifying Respirator Replacement Parts:

Part No.	Description
AP1-15XX-US	Vision® facepiece (XX = color/paint option as follows: 00 = Black, 23 = Speedway, 26 = Red Rock, 33 = Dragon Fire, 43 = Dream Weaver, 68 = Easy Rider)
AP-HFS-01	Face Seal
AP-BLW-02	Blower Unit
AP-BAT-02	Battery
AP-WBT-01	Belt
AP-FIL-03	HE Filter
AP-CHG-01	US Charger
AP-BT-01	Breathing Tube
AP-BT-FR	Fire Retardant Hose cover
AP-AIRDUCT-01	Headgear and Airduct Assembly

5.2 Technical Specifications

Blower Unit:

Type: Flow Control

Rotor Speed: 6,000-10,000 rpm

Rotor: Brushless

Noise Level: ≈ 65 dBA

Air Supply: minimum of 6 cubic feet (170 liters) / min

Case: Impact-proof ABS

Belt Plate: Fiber Glass reinforced polyamide

Filter Cartridge: Single plug-in type

Hose Length: 29.5 in (750 mm)

Hose Diameter (internal): 1.06 in (27 mm)

Hose Connection: Bayonet Connection

Weight: 1.4 lbs (0.63 kg)

Dimensions: 6.9 in x 4.2 in x 7.5 in (174 mm x 107 mm x 191 mm)

Color: Black and Blue

Battery:

Type: Lithium-Ion

Voltage: 7.4 V

Current Hours: 7800 mAh

Operating Time (Fully charged battery): twelve (12) hours at minimum speed / six (6) hours at maximum speed

Charging Time: 5-7 hours

Charging Cycles: 350 (under ideal conditions)

Housing: Impact-proof ABS

Weight: .78 lb (0.35 kg)

Dimensions: 5.9 in x 2.9 in x 1.65 in (150 mm x 74 mm x 42 mm)

Color: Black

Charger:

Type: DC Rectifier

Primary Voltage: 120 V / 60Hz

Secondary Voltage: 7.4 V

Output Current: 570 mA

Weight: 0.24 lb (0.110 kg)

Dimensions: 4.65 in x 2.4 in x 2.75 in (118 mm x 62 mm x 70 mm)

Color: Black

Approvals: UL/CSA/CE

Welding Helmet Headtops:

Material (Welding Helmet): Nylon

Weight: 1.23 lbs (0.56 kg) (Vision®)

Colors: Black or Decaled (various styles)

Approvals: ANSI Z87.1, CAN/CSA Z94.3

Auto-Darkening Lens:

See the **ArcONE®** Auto-Darkening Filters User Instruction Manual for lens specifications.



5.3 Warranty and Technical Service Information

ARCONE® warrants the AIRPLUS® PAPR System for one (1) year from the date of purchase against all manufacturing defects resulting from materials or workmanship, excluding the auto-darkening lens. Refer to the Auto-Darkening Welding Filter manual for warranty information regarding welding filters. Proof of purchase establishing sale date of the respirator system and applicable components must be provided, should a warranty claim be submitted. The purchaser's only remedy under this limited warranty shall be limited to ARCOONE's sole option to repair, replace or refund (not to exceed the purchase price). This limited warranty is void in the case of unauthorized modification, tampering, and damage due to misuse, abuse, inadequate maintenance or improper storage. This limited warranty is not transferable from the original purchaser to a secondary owner. ARCOONE® shall in no event be liable or responsible for the use or misuse of this product. This limited warranty is exclusive and is in lieu of any other warranty implied, either oral or written. Please read the instruction manual carefully to avoid certain situations which may void this limited warranty.

For Warranty or Non-Warranty repairs or replacements please proceed as follows:

**PLEASE DO NOT CONTACT THE DISTRIBUTOR OR RETAILER
FROM WHOM YOU PURCHASED THE RESPIRATOR.**

1. Contact ARCOONE® Technical Service (800-223-4685) for a Return Goods Authorization Number (RGA).
2. Send the complete respirator, freight prepaid, in a box with packaging material to protect the product from damage, directly to:

ARCONE® Technical Service
85 Independence Drive
Taunton, MA 02780

Reference your assigned Return Goods Authorization Number on the outside of the package and on all accompanying paperwork.

3. Provide a brief description of the problem. Provide Return Shipping information. Complete information will help to expedite the process.
4. Before returning the respirator, decontaminate and clean it to remove any hazardous materials which may have settled on the respirator during use. Laws and/or regulations prohibit the shipment of hazardous or contaminated materials. Respirator(s) suspected to be contaminated will be professionally discarded at the customer's expense.
5. Visa, MasterCard, or checks are the only forms of payment accepted. In the case of credit cards, please call Technical Support with credit card number, expiration date, the full name as it appears on the credit card, and your signature as authorization for the total repair amount.
6. All warranty repairs are covered for the balance of the original warranty period.
7. All non-warranty repairs carry a 90-day, limited warranty.



ARCONE® IS A DIVISION OF A.C.E. INTERNATIONAL COMPANY

85 Independence Drive, Taunton, MA 02780

TEL: (508)-884-9600 • TOLL FREE: (800) 223-4685 • FAX: (508) 884-9666

Please visit our website and register product at: www.arc1weldsafe.com