



USER INSTRUCTION MANUAL

Carrera™ **ARCONE**® Helmet with Auto-Darkening Filters



85 Independence Drive, Taunton, MA 02780

Tel: 508-884-9600 Toll Free: 800-223-4685

Fax: 508-884-9666

Please visit our website and register at www.arc1weldsafe.com

CARRERA-01-UIf

TABLE OF CONTENTS	PAGE
Preparations for Use	1
Technical Information/Use	2
Limitations of Use	3
Care and Maintenance	3
Spatter Protection	4
Parts Selection Guide	4
Filter Removal Instructions	5
Significance of Markings	5
Filter Specifications	6
Warranty and Service Information	7

Preparations for Use

FILTERS:

Before you begin welding always inspect your filter to ensure it is not damaged. Check to see if the filter protection plates (cover plates) are clean, clear, undamaged, and securely attached to the helmet and covering the auto-darkening filter both front and rear.

To test your filter, prior to welding, direct the front of the filter to a bright source of light then, using your fingers, rapidly cover and uncover the sensors. The filter will darken momentarily. Another means of testing is to utilize a torch striker or TV or VCR remote. These devices will also momentarily darken the filter. Once you are sure that the filter is working properly you are now ready to begin welding.

WARNING, Never begin welding without first checking to see if the correct front protection plate is in place (see Part Selection Guide section for part numbers), the filter is secured properly in the filter holder, and the filter holder secured in the helmet . Failure to protect the welding filter or install the filter/filter holder correctly may cause damage and become a safety hazard should the UV/IR protection be compromised from spatter or cracks from impact. DAMAGE CAUSED BY ABUSE SUCH AS EXCESSIVE TEMPERATURES, CRACKS FROM IMPACT, AND PITTING FROM SPATTER CAUSED BY POOR MAINTENANCE WILL VOID WARRANTY.

WELDING HELMETS:

Before you begin welding make sure there is no damage to the helmet shell including, but not limited to cracks, holes, and melting. Ensure that the springs holding the filter are not broken or corroded. Do not use the helmet if any of these conditions exist and contact your distributor for replacement parts.

WARNING, Secondary impact protection required. Other safety precautions such as protective clothing, adequate ventilation, breathing protection, fire extinguisher, and protection for co-workers, should also be considered.

Not for use in overhead welding.

WARNING, Materials which may come into contact with the wearer's skin could cause allergic reactions to susceptible individuals.

HEADGEAR:

Adjust the crown height via the pin hole adjustment on the top strap of the headgear (see Figure1).
Adjust the circumference by turning the rear knob while wearing.

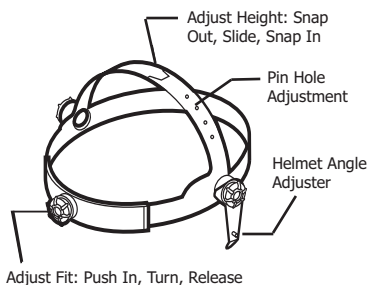

Figure 1

Technical Information/Use

FILTERS:

ArcONE® auto-darkening filters protect the user against harmful ultra-violet and infrared UV/IR rays, both in the dark and light state. **No matter what shade the filter is set to the UV/IR protection is always there. When used as instructed, you will never burn your eyes due to optical radiation.**

WARNING, Severe burns are possible with a damaged lens (cracks, pits, holes, etc.). Do not use a damaged lens.

Note: Optical radiation may enter in from behind the helmet from other welders welding in the immediate area.

Filter Specific Features

1000FcF and 4500V: Adjust Sensitivity, Shade, and Delay with the knobs on the back of the filter (see Figure 2). Activate the Grind Mode by turning the Sensitivity knob counter-clockwise past the white line; the knob will lock into Grind Mode. Deactivate the Grind Mode by setting the Sensitivity to any setting above the white line. Other functions will not work in Grind Mode.

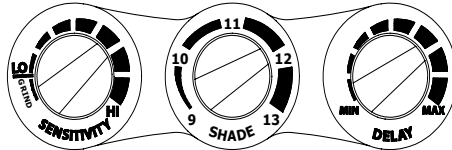

Figure 2: 1000FCF and 4500V Controls

1500V and 2000V: Adjust the Shade with the knob on the outside of the helmet (see Figure 3). Adjust Sensitivity and Delay with the knobs on the back of the filter (see Figure 4). These models do not have Grind mode.

2500V: Adjust Sensitivity, Shade, and Delay with the knobs on the back of the filter. This model does not have Grind mode (see Figure 5).

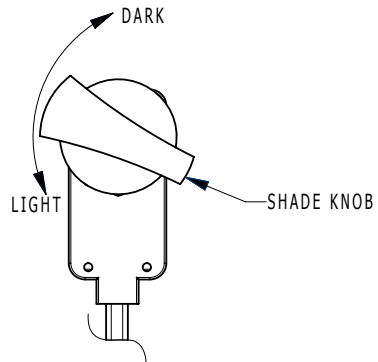

Figure 3: Outside Shade Control

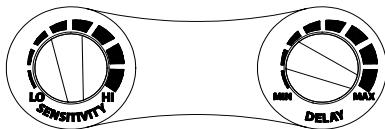

Figure 4: 1500V and 2000V Controls

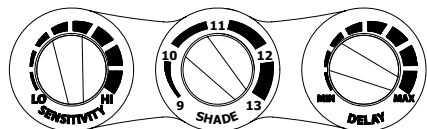

Figure 5: 2500V Controls

WELDING HELMETS:

Welding helmets are designed to provide protection against UV/IR radiation around the user's face. **ArcONE**® welding helmets meet/exceed face coverage defined by CE standards. Welding helmets are made of a durable, modern material capable of use in a variety of environments.

Limitations of Use

See also, Significance of Markings (page 5).

FILTERS:

ArcONE® welding filters **ARE NOT** designed for oxy-acetylene, laser, or very low amperage welding applications. Arc detection may be impaired due to amperage, distance from the arc, welding current frequency, electrode type, shielding gasses, and lighting conditions.

Do not weld with filter in the light state. If the filter fails to turn dark immediately stop use and contact a service provider for help.

WARNING, Eye-protectors against high speed particles worn over standard ophthalmic spectacles may transmit impacts, thus creating a hazard to the wearer.

WARNING, Toughened mineral oculars shall only be used in conjunction with a suitable backing ocular.

WELDING HELMETS:

Not meant to protect against severe impact, explosives, fragments from grinding wheels, and abrasive discs, and hazardous fluids.

Do not use this helmet without proper training from a certified welder or welding instructor.

Do not use this helmet in an excessive heat environment where the operation of the filter becomes non-functional due to exceeding the temperature ratings of the electronic components.

Care and Maintenance

NOTE: Replacement components must be used in accordance with these instructions. Failure to use ArcONE® replacement components in accordance with these instructions voids certification and warranty of this product.

FILTERS:

Filters require virtually no maintenance other than periodic cleaning when the lens, solar panel, and/or sensors become dirty or clouded from smoke. Clean your filter by using window cleaner or a mild soapy solution and a soft cloth or paper towel (do not immerse in water or solution). Ensure that the sensors are kept clean and unobstructed. Change the cover plates frequently.

WARNING, Replace scratched or damaged oculars

WELDING HELMETS:

Welding helmets require virtually no maintenance other than periodic cleaning when dirty. Clean your helmet by using a mild soapy solution and a soft cloth or paper towel (do not immerse in water or solution).

WARNING, DO NOT throw or abuse the helmet. Doing so may crack the helmet shell or filter, which may compromise the protection causing serious injury or loss of life.

Store in an appropriate place to prevent damage when not in use (See Table 1: Storage Temperature). Welding helmets may be stored and transported in their original or similar packaging.

POLYCARBONATE PROTECTION (COVER) PLATE:

CAUTION, Change cover plates when they lose flexibility and/or become bowed or distorted. Clean with mild soapy solution including any build-up from the area where the cover plate is retained. Discard if cleaning fails to improve visibility. Discard if cracks, scratches, or other marks impair visibility.

Spatter Protection

Ensure the front cover plate is secure under all the tabs (see Figure 6) located inside the Carrera™ **ArcONE**® Welding Helmet and within the area covered by the filter holder.

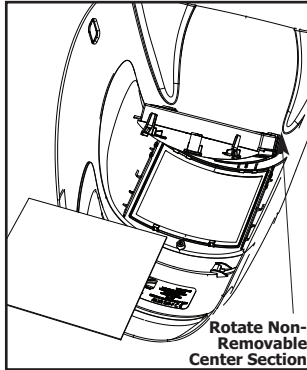

Figure 6

SPATTER DAMAGE IS NOT COVERED BY WARRANTY

All cover plates are 1 mm thick.

*****To install, slide Polycarbonate under top tabs then push underneath bottom tabs*****

Parts Selection Guide

(see Filter Removal Diagram for replacing Filter and Cover Plates)

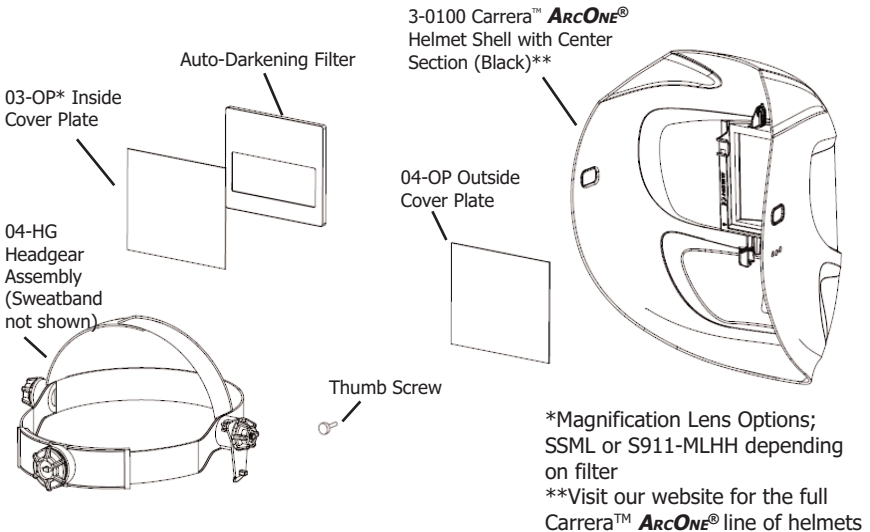

Figure 7

Filter Removal Instructions

Removable Filter Holder

1. Grab filter by top and bottom edge
2. Pull up on bottom edge of filter and slide out of the bottom of the filter holder (see Figure 8)

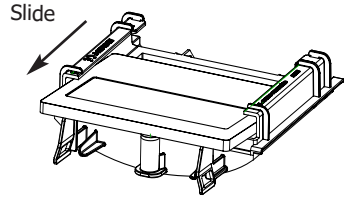

Figure 8



Critical Installation Warning!

Helmet impact rating Z87+ with Thumb Screw installed. Helmet rating Z87 without thumb screw. For Z87+ make sure Filter Holder Center Tab is secured to the Welding Helmet Centering Pin with Thumb Screw (See Figure 9). **Do not over tighten.**

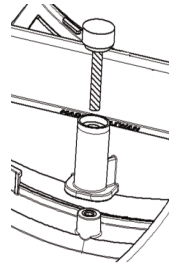

Figure 9

Significance of markings on Auto-Darkening Filters:

Example: 4 / 9-13 AR 1/3/1 EN379

CE - European Conformity Mark

4 - Light Shade number

9 - Dark Shade range 1

13 - Dark Shade range 2

AR - Manufacturers mark

1 - Optical Class

3 - Diffusion of Light Class

1 - Variation in Luminous

Transmittance Class

EN379 - Standard for Auto-Darkening welding filters

These models have been certified by:

DIN CERTCO

Gesellschaft für Konformitätsbewertung mbH

Alboinstr. 56

D-12103 Berlin

Notified Body Number: 0196

Significance of CE Markings on Carrera™ ARCONE® Welding Helmet**:

Example: AR EN 175 -F CE

AR - Company Identification Mark

EN 175 - CE Welding Helmet Standard

-F - Impact Class,

CE - European Mark

This model has been certified by:

INSPEC

56 Leslie Hough Way

Salford

Greater Manchester

M6 6AJ, England

Notified Body Number: 0194

Note: In situations where protection against high speed particles at extreme temperatures is required, use only eye-protectors with the letter T immediately following the impact class letter, i.e., -FT, BT or AT. If the impact class letter is not followed by the letter T then the eye protector shall only be used against high speed at room temperature.

Table 1: Filter Specifications

	1000FcF	1500V	2000V	2500V	4500V
Viewing Area (mm²)	3864	4416	4704	4704	4752
Filter Size (mm)	90x110	90x110	90x110	90x110	90x110
ARC Sensing	Two sensors	Two sensors	Two sensors	Two sensors	Four sensors
Sensitivity Control	Variable	Variable	Variable	Variable	Variable
Switching Time (seconds)	1/10,000 (0.1ms)	5/10,000 (0.5ms)	1/10,000 (0.1ms)	1/10,000 (0.1ms)	1/10,000 (0.1ms)
Primary Power	Solar Cells	Solar Cells	Solar Cells	Solar Cells	Solar Cells
Back-up Power	Lithium Battery	Lithium Battery	Lithium Battery	Lithium Battery	Lithium Battery
Operating Temperature	14-131F (-10-55C)	14-131F (-10-55C)	14-131F (-10-55C)	14-131F (-10-55C)	14-131F (-10-55C)
UV / IR Protection	Up to Shade 16	Up to Shade 16	Up to Shade 16	Up to Shade 16	Up to Shade 16
Dark to Light Delay (seconds)	0.2 to 2	0-2	0-2	0.2-2	0.2 to 2
Light Shade	4	4	4	4	4
Dark Shade	9-13	9-13	9-13	9-13	9-13
Grind Mode	Yes	No	No	No	Yes
Enclosure Integrity	Not Dust/Water Resistant	Not Dust/Water Resistant	Not Dust/Water Resistant	Not Dust/Water Resistant	Not Dust/Water Resistant
Standards	CE EN379	CE EN379	CE EN379	CE EN379	CE EN379
Optical Class	1	1	1	1	1
Diffusion of Light Class	2	2	2	2	2
Variation in Luminous Transmittance Class	1	1	1	1	1
Angle Dependency Class	3	3	3	3	3
Inside Cover Plate	03-OP	03-OP	03-OP	03-OP	03-OP

Warranty and Service Information

LIMITED WARRANTY

ARCONE® warrants all auto-darkening filters listed in this manual for a period of three (3) years from the date of purchase against all manufacturing defects resulting from materials or workmanship. Other components are warranted for a period of ninety (90) days. Proof of purchase establishing the date of sale and filter serial number must be provided, should a warranty claim be submitted. The purchaser's only remedy under this limited warranty shall be limited to **ARCONE**® sole option to repair, replace or refund (not to exceed the purchase price). This warranty is void in the case of unauthorized modification, tampering, and damage due to misuse, abuse, inadequate maintenance or improper storage. Some indications of operator abuse include, but are not limited to, spatter, chips, dents or cracks. This limited warranty is not transferable from the original purchaser to a secondary owner. **ARCONE**® shall in no event be liable or responsible for any injury, damage or loss resulting either directly or indirectly from the use or misuse of this product. This limited warranty is exclusive and is in lieu of any other warranty implied either oral or written. Please read the instruction manual carefully to avoid certain situations which may void this limited warranty.

RETURN PROCEDURE

Note: If outside the United States, please contact the distributor from whom you purchased your equipment.

1. Remove the auto-darkening filter from the helmet. Record the model number and serial number which are located on the filter edge or back. Also record the date of purchase from your sales receipt.
2. Contact **ARCONE**® Technical Service (800-223-4685) for a Return Authorization Number.
3. Return the lens only, freight pre-paid, in a box with packaging material to prevent damage, no envelopes, please. Reference the Return Authorization Number on the box and any accompanying paperwork. Include your contact information and return address (no P.O. Boxes, please).

PLEASE CONTACT

ARCONE® Technical Service

Telephone: 800-223-4685, Fax: 508-884-9666

Please Visit Our Website

&

Register Your Product

www.arc1weldsafe.com