



WELDING AND SAFETY PRODUCTS

USER INSTRUCTION MANUAL CARRERA HELMET with AUTO-DARKENING FILTER



85 Independence Drive, Taunton, MA 02780
Tel: 508-884-9600 Toll Free: (800) 223-4685
Fax (508) 884-9666 www.arc1weldsafe.com

TABLE OF CONTENTS	PAGE
Preparations for Use	1
Technical Information / Use	2-3
Limitations of Use	3
Care and Maintenance	3
Spatter Protection	4
Parts Selection Guide	4-5
Filter Specifications:	6
Shade Selection Guide	6
Filter Removal Diagram	7
Troubleshooting Guide	7-8
Warranty and Service Information	9-10

Preparations for Use

FILTERS:

Before you begin welding always inspect your filter to ensure it is not damaged. Check to see if the filter protection plates (cover plates) are clean, clear, undamaged, and securely attached to the helmet and covering the auto-darkening filter both front and rear.

To test your filter, prior to welding, direct the front of the filter to a bright source of light then, using your fingers, rapidly cover and uncover the sensors. The filter will darken momentarily. Another means of testing is to utilize a torch striker or TV or VCR remote. These devices will also momentarily darken the filter. Once you are sure that the filter is working properly you are now ready to begin welding.

WARNING, never begin welding without first checking to see if the correct front protection plate is in place, the filter is secured properly in the filter holder, and the filter holder secured in the helmet (See Part Selection Guide section for part numbers). Failure to protect the welding filter or install the filter / filter holder correctly may cause damage and become a safety hazard should the UV/IR protection be compromised from spatter or cracks from impact. DAMAGE CAUSED BY ABUSE SUCH AS EXCESSIVE TEMPERATURES, CRACKS FROM IMPACT, AND PITTING FROM SPATTER CAUSED BY POOR MAINTENANCE WILL VOID WARRANTY.

WELDING HELMETS:

Before you begin welding make sure there is no damage to the helmet shell including, but not limited to cracks, holes, and melting. Ensure that the springs holding the filter are not broken or corroded. Do not use the helmet if any of these conditions exist and contact your distributor for replacement parts.

WARNING, other safety precautions such as protective clothing, adequate ventilation, breathing protection, such as a Clean Air Flow PAPR, SAR or equal, fire extinguisher, and protection for co-workers, should also be considered.

WARNING, Materials which may come into contact with the wearer's skin could cause allergic reactions to susceptible individuals.

The Welding Helmet is equipped with a headgear that has both crown (height) and circumference adjustments (see Figure 1). Adjust the crown height via the pin/hole adjustment on the top strap of the headgear. The circumference is easily adjusted by means of a knob located at the back; this adjustment can be performed as you wear your welding helmet.

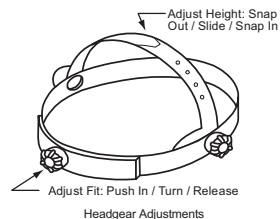

Figure 1

Technical Information / Use

FILTERS:

ARCONE® auto-darkening filters protect the user against harmful ultra-violet and infrared UV/IR rays, both in the dark and light state. **No matter what shade the filter is set to the UV/IR protection is always there. You can never burn your eyes due to optical radiation.**

Warning: Severe burns are possible with a damaged lens (cracks, pits, holes, etc.). Do not use damaged lens. Optical radiation can possibly enter in from behind the helmet from other welders welding in the immediate area.

SHADE ADJUSTMENT

See CE EN169 Shade Selection Guide for recommended shades for arc welding applications. See Filter Specification section for filter specifications.

FIXED SHADE FILTERS:

When arc is struck the filter automatically darkens to the predetermined dark shade (see Table 1).

ANALOG CONTROLLED VARIABLE SHADE ADJUSTMENT

External (see Figure 2): manually control the shade adjustment on the exterior of the welding helmet

Internal (see Figure 3): manually control dark shade with the shade knob located on the filter inside of the helmet.

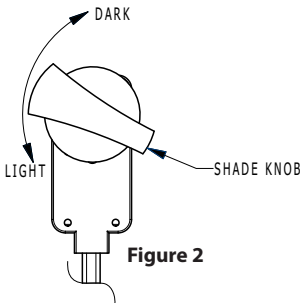
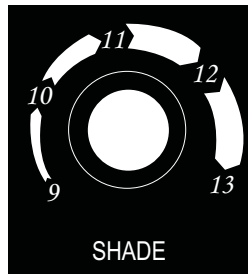
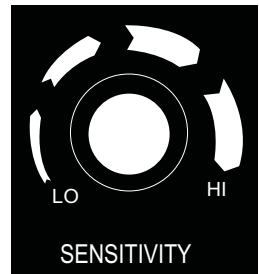

Figure 2



SHADE

Figure 3



SENSITIVITY

Figure 4

ANALOG CONTROLLED SENSITIVITY ADJUSTMENT

(see Figure 4): manually control the sensitivity knob located on the filter inside of the helmet to adjust sensitivity. Note: the lowest setting may keep the filter in the light state when used for grinding.

DELAY ADJUSTMENT AND GRIND MODE

Change the Delay by quickly pressing and releasing the Delay/Grind button (see Figure 5). The red DELAY light will turn on. Press the Delay/Grind button again to turn off. To activate the grind mode, press and hold down the Delay/Grind button until the red GRIND light turns on. Deactivate Grind mode by quickly pressing and releasing the Delay/Grind button again.



Figure 5

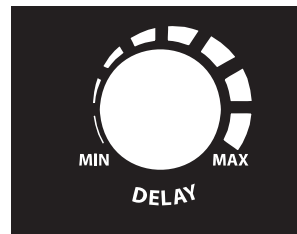

DELAY

Internal on the 2000V

Figure 6

Technical Use (continued)

WELDING HELMETS:

Welding helmets are designed to provide protection against UV/IR radiation around the user's face. **ARCONE**® welding helmets meet/exceed face coverage defined by CE standards.

Welding helmets are made of a durable, modern material capable of use in a variety of environments.

Limitations of Use

WARNING, Eye-protectors against high speed particles worn over standard ophthalmic spectacles may transmit impacts, thus creating a hazard to the wearer

FILTERS:

ARCONE® welding filters **ARE NOT** designed for oxy-acetylene, laser, or very low amperage welding applications. Arc detection may be impaired due to amperage, distance from the arc, welding current frequency, electrode type, shielding gasses, and lighting conditions.

Do not weld with filter in the light state. If the filter fails to turn dark immediately stop use and contact a service provider for help.

Warning, toughened mineral filter oculars shall only be used in conjunction with a suitable backing ocular. In other words, use secondary eye protection underneath helmet via spectacles or goggles.

WELDING HELMETS:

Not meant to protect against Severe Impact, explosives, fragments from grinding wheels, and abrasive discs, and hazardous fluids.

Do not use this helmet without proper training from a certified welder or welding instructor.

Do not use this helmet in an excessive heat environment where the operation of the filter becomes non-functional due to exceeding the temperature ratings of the electronic components.

Care and Maintenance

NOTE: Replacement components must be used in accordance with these instructions. Failure to use ArcOne replacement components in accordance with these instructions voids certification of this product.

FILTERS:

Filters require virtually no maintenance other than periodic cleaning when the lens, solar panel, and/or sensors become dirty or clouded from smoke. Clean your filter by using window cleaner or a mild soapy solution and a soft cloth or paper towel (do not immerse in water or solution). Ensure that the sensors are kept clean and unobstructed. Change the cover plates frequently.

WELDING HELMETS:

Welding helmets require virtually no maintenance other than periodic cleaning when dirty. Clean your helmet by using a mild soapy solution and a soft cloth or paper towel (do not immerse in water or solution).

Warning, DO NOT throw or abuse the helmet. Doing so may crack the helmet shell or filter, which may compromise the protection causing serious injury or loss of life.

Store in an appropriate place to prevent damage when not in use (See Table 1: Storage Temperature). Welding helmets may be stored and transported in their original or similar packaging.

POLYCARBONATE PROTECTION (COVER) PLATE:

Caution: Change cover plates when they lose flexibility and/or become bowed or distorted. Clean with mild soapy solution including any build-up from the area where the cover plate is retained. Discard if cleaning fails to improve visibility or cracks, scratches, etc. impair visibility.

Spatter Protection

Ensure the front cover plate is secure under all the tabs (see Figure 7A & 7B) located inside the Carrera Welding Helmet and within the area covered by the filter holder..

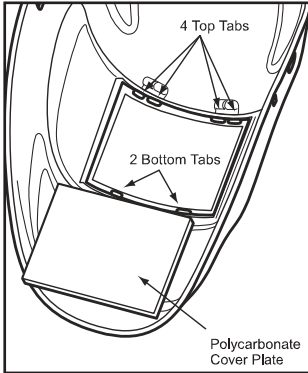

Figure 7A

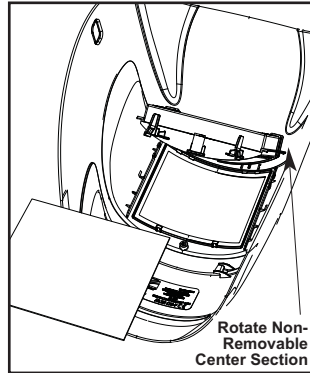

Figure 7B

SPATTER DAMAGE IS NOT COVERED BY WARRANTY

All cover plates are 1 mm thick.

*****To install, slide Polycarbonate under top tabs then push underneath bottom tabs*****

Parts Selection Guide (Removeable Center Section)

(see Filter Removal Diagram for replacing Filter and Cover Plates)

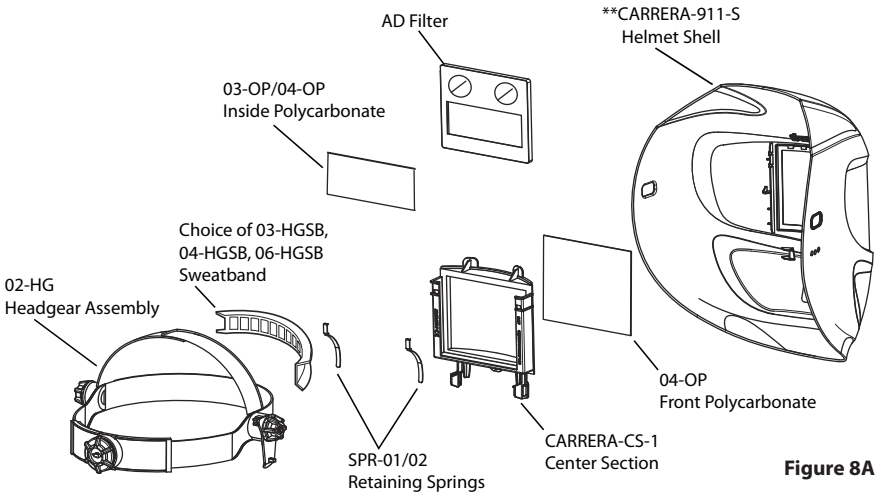

Figure 8A

Parts Selection Guide (Non-Removeable Center Section)

(see Filter Removal Diagram for replacing Filter and Cover Plates)

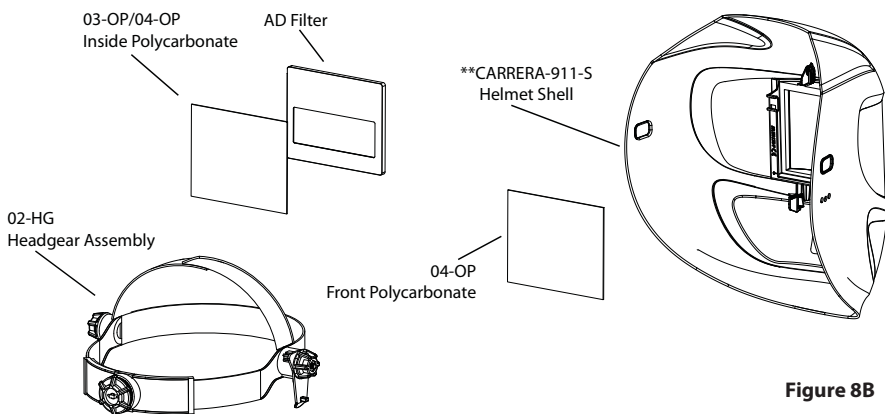

Figure 8B

Significance of markings on Auto Darkening Filters:

Example: 4 / 9-13 AR 1/3/1 EN379

CE - European Conformity Mark

4 - Light Shade number

9 - Dark Shade range 1

13 - Dark Shade range 2

AR - Manufacturers mark

1 - Optical Class

3 - Diffusion of Light Class

1 - Variation in Luminous Transmittance class

EN379 - Standard for Auto-Darkening welding filters

**This model has been certified by:*

Certottica SCARL

Zona Industriale Villanova

32013 Longarone (BL), Italy

Notified Body Number: 0530

*Model Certified by: ***DIN CERTCO*

Gesellschaft für Konformitätsbewertung mbH

Albainstr. 56

D-12103 Berlin

Notified Body Number: 0196

Significance of CE Markings on Carrera Welding Helmet**:

Example: AR EN 175 -F CE

AR - Company Identification Mark,

EN 175 - CE Welding Helmet Standard,

-F - Impact Class,

CE - European Mark

***This model has been certified by: INSPEC*

56 Leslie Hough Way

Salford

Greater Manchester

M6 6AJ, England

Notified Body Number: 0194

Warning, In situations where protection against high speed particles at extreme temperatures is required, use only eye-protectors with the letter T immediately following the impact letter, i.e., -FT, BT or AT. If the impact letter is not followed by the letter T then the eye protector shall only be used against high speed particles at room temperature.

Filter Specifications (Table 1)

	2000T	1000FcF	2000V
Viewing Area	3290 mm ²	3290 mm ²	4704 mm ²
Filter Size (mm)	90x110	90 X 110	90 X 110
ARC Sensing	Two sensors	Two sensors	Two sensors
Sensitivity Control	Fixed	Variable	Variable
Switching Time (seconds)	5/10,000 (0.5 milliseconds)	1/10,000 (0.1 milliseconds)	5/10,000 (0.5 milliseconds)
Primary Power	Solar Cells	Solar Cells	Solar Cells
Back-up Power	Lithium Battery	Lithium Battery	Lithium Battery
Operating & Storage Temperature	14 – 131F (-10 – 55C)	14 – 131F (-10 – 55C)	14 – 131F (-10 – 55C)
UV / IR Protection	Up to Shade 16	Up to Shade 16	Up to Shade 16
Dark to Light Delay	0.1 seconds	0.1 & 2 seconds	0 - 2 seconds
Light Shade	3	4	4
Dark Shade	11	9-13	9-13
Grind Mode	No	Yes	No
Enclosure Integrity	Not Dust / Water Resistant	Not Dust / Water Resistant	Dust / Water Resistant
Standards	CE EN379	*CE EN379	***CE EN379
Optical Class	1	1	1
Diffusion of Light Class	2	3	3
Variation in Luminous Transmittance Class	1	1	1
Angle Dependency Class	N/A	N/A	3

*Certottica certified

Shade Selection Guide

CE Shade selection Guide (Table 2)

Process	Current (Amps)																					
	1.5	6	10	15	30	40	60	70	100	125	150	175	200	225	250	300	350	400	450	500	600	
Covered Electrodes	8			9				10			11			12			13			14		
MAG	8			9				10			11			12			13			14		
TIG	8			9				10			11			12			13					
MIG with heavy metals	8			9				10			11			12			13			14		
MIG with light metals	8			9				10			11			12			13			14		
Air-arc gouging	8			9				10			11			12			13			14		
Plasma jet cutting	8			9				10			11			12			13					
Micro-plasma arc welding	4	5	6	7	8	9	10	11	12	15	175	200	225	250	300	350	400	450	500	600		
	1.5	6	10	15	30	40	60	70	100	125	150	175	200	225	250	300	350	400	450	500	600	

NOTE: The term "heavy metals" applies to steels, alloy steels, copper and its alloys, etc.

***From CE EN 169:2002

Removable Center Section

1. First, the plastic knob must be removed from the outside of the helmet, then the nut and washer come off. The potentiometer will then slide through the back of the helmet.
2. Squeeze Bottom Tabs of the filter holder together until they disengage from the Catches on the Welding Helmet. Then lift Filter Holder out of Welding Helmet. (Removable filter holder only).
3. Slide Auto Darkening Filter and Inside Polycarbonate out of Filter Holder.

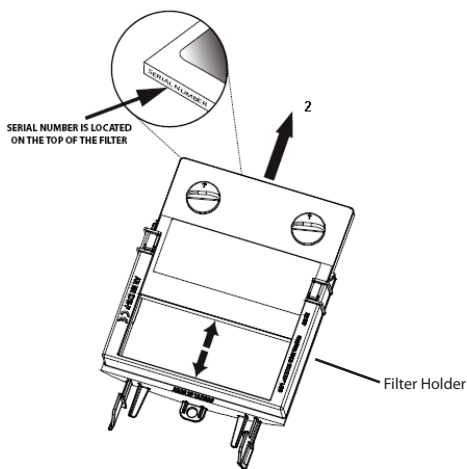

Figure 9

Trouble Shooting Guide

It has become difficult to see through the filter

- Replace cover plates when they become dirty or discolored with ArcOne cover plates.
- Clean the auto-darkening filter as directed in the Care and Maintenance Section, page 5.

The Auto-Darkening Filter will not darken after striking an arc

- Test the auto-darkening filter as directed in "Preparation for use" section page 2.
- Make sure that the outer cover plate is clean, clear and unobstructed.
- Remove and inspect the auto-darkening filter making sure that the sensors and solar panels are unobstructed, clean and not broken or discolored.
- Cease using this product if problem persists and Contact **Technical Service at 800-223-4685**.

The Auto-Darkening Filter is slow to darken

- **ARCONE**® solar powered auto-darkening filters are designed to operate on very low voltage. If the filter has not been used for a period of time, such as a day or more, the circuitry will enter a sleep state. In the sleep state the battery can retain full voltage potential. It will awaken when you test it or begin welding. For instance if the product is at shade 10, the first time it darkens it will initially darken to perhaps shade 8 then transition to shade 10. Then after that it will darken to shade 10 each and every time. **Note: As long as you are wearing your helmet with auto-darkening filter you are protected from UV/IR (ultra-violet/infrared) rays in the dark and light state and every shade in between.**

- Colder temperatures will slow the switching speed of an auto-darkening filter. Once the heat from welding process warms up the components, switching speeds will increase. Auto-darkening filters work best at room temperatures.

The Auto-Darkening Filter goes light or flickers on/off while welding

- Clean or replace outer clear polycarbonate lens if it becomes soiled or cloudy
- Check to make sure that the sensors and solar panels are not damaged, dirty, or covered with a smoky film. Clean filter as directed in Care and Maintenance Section on page 4.
- Make sure that the sensors and solar panels are not being blocked. Your arms, the welding torch or other objects can block the sensor or solar panels.
- The front of the auto-darkening filter should be perpendicular to the welding arc.
- If the Filter does not hold the dark shade contact Technical Service at 800-223-4685.

The Auto-Darkening Filter stays dark after you stop welding

- Exceeding the temperature limitations may also cause the LCD to stay dark. Let the filter cool down and try not to overheat it again by viewing the arc from the side and not directly above or by increasing the distance the filter is in relationship to the arc.
- Your filter may remain dark after welding if you are facing a bright light or the sun. If this is the case either look away or pass your hand between the source of light and the sensors. By doing this the light source will be interrupted and the filter will clear.

The Auto-Darkening Filter has a crack running through the front viewing area

- The UVIR protection may be compromised resulting in burns caused by Ultraviolet or Infrared radiation. Cease using this product if the problem exists and Contact **Technical Service at 800-223-4685.**

The Auto-Darkening Filter appears dark in the center and lighter around the edges

- You are most likely experiencing a common characteristic of an LCD known as angle dependency. This characteristic may make the lens appear to be darker in the center and lighter toward the outer edges when the lens is viewed at an angle not perpendicular to the filter's surface or not perpendicular to the arc.

Spatter is causing damage to the filter

- Please refer to the Spatter Protection section on page 4.

The Auto-darkening Filter has severe spatter damage

- Do not operate this product if this condition exists. The UVIR protection may be compromised. Unfiltered welding light may penetrate through the filter and may result in severe eye damage and burns.

Warranty and Service Information

LIMITED WARRANTY

ARCONE® warrants all auto-darkening filters covered by this manual for two (2) years from the date of purchase against manufacturing defects resulting from materials or workmanship. Proof of purchase establishing the date of sale and filter serial number must be provided, should a warranty claim be submitted. The purchaser's only remedy under this limited warranty shall be limited to **ARCONE's** sole option to repair, replace or refund (not to exceed the purchase price). This limited warranty is void in the case of unauthorized modification, tampering, and damage due to misuse, abuse, inadequate maintenance or improper storage. This limited warranty is not transferable from the original purchaser to a secondary owner. **ARCONE®** shall in no event be liable or responsible for any injury, damage or loss resulting either directly or indirectly from the use or misuse of this product. This limited warranty is exclusive and is in lieu of any other warranty implied either oral or written. Please read the instruction manual carefully to avoid certain situations which may void this limited warranty.

PLEASE CONTACT
ARCONE Service Center
Telephone: 800-223-4685, Fax: 508-884-9666
Or
Visit Our Website
www.arc1weldsafe.com



A Division of A.C.E. International Company, Incorporated
85 Independence Drive, Myles Standish Industrial Park, Taunton, MA 02780
Tel: 508-884-9600 or 800-ACE-INTL (223-4685) Fax: 508-884-9666